

THE INFORMATION CONTAINED IN THIS DRAWING IS THE SOLE PROPERTY OF THE RANDOLPH AUSTIN CO.. ANY REPRODUCTION IN PART OR WHOLE WITHOUT THE WRITTEN PERMISSION OF THE RANDOLPH AUSTIN CO. IS PROHIBITED.

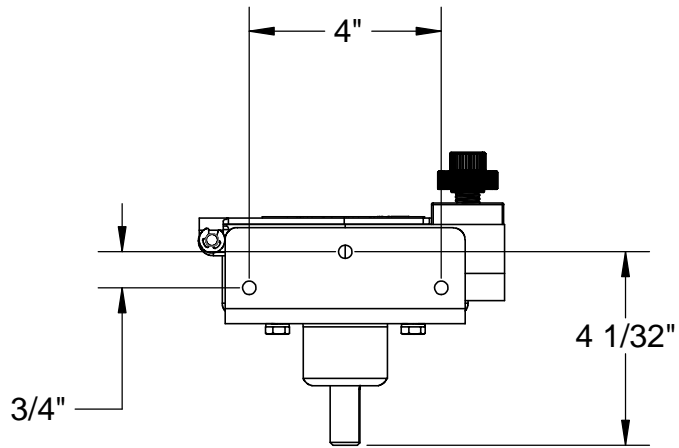

UNLESS OTHERWISE SPECIFIED
DIMENSIONAL TOLERANCES ARE:
FRACTIONS DECIMALS ANGLES
MILLIMETERS:
N/A ±.127 ±.5°
INCHES:
±1/64 ±.005 ±.5°

CAD GENERATED DRAWING.
DO NOT MANUALLY UPDATE

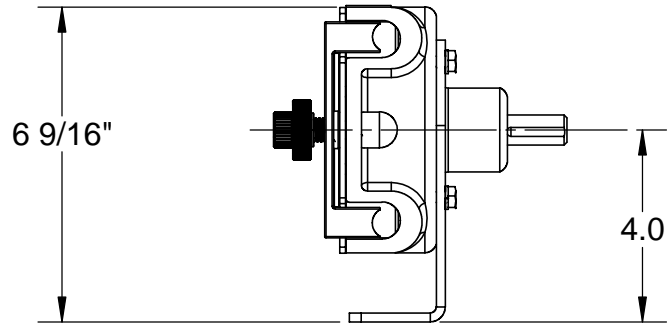
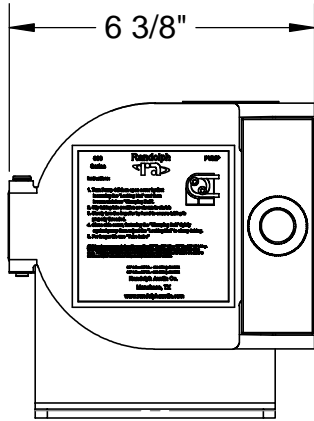

2119 FM 1626
MANCHACA TX. 78652
(512) 282-1590

APPROVALS		DATE
DRAWN		8/4/2020
CHECKED		
RESP ENG		
MFG ENG		
QUAL ENG		

620-PHO Mounting
Dimensions, Exploded View
and BOM

SIZE	DWG. NO.	REV.
A	620-PHO	
SCALE	CAD FILE: 620-PHO	SHEET 1 OF 3

NEXT ASSY	USED ON
APPLICATION	DO NOT SCALE DRAWING

SEE NOTES

SEE NOTES

DO NOT SCALE DRAWING

THE INFORMATION CONTAINED IN THIS DRAWING IS THE SOLE PROPERTY OF THE RANDOLPH AUSTIN CO.. ANY REPRODUCTION IN PART OR WHOLE WITHOUT THE WRITTEN PERMISSION OF THE RANDOLPH AUSTIN CO. IS PROHIBITED.

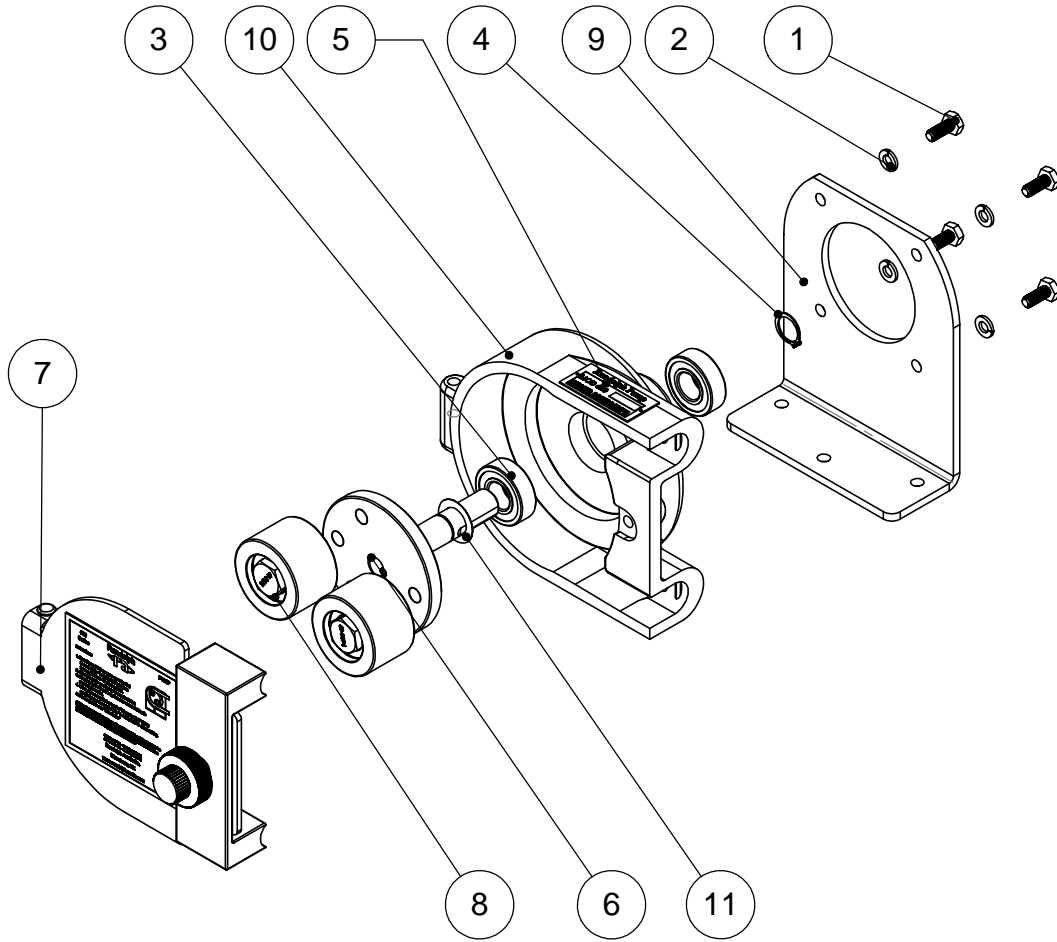

ITEM NO.	PART #	Desc.	Qty
9	00-0014	1/4-20 x .625 HH	4
7	00-0252	1/4" Lock Washer	4
3	01-0113	Bearing	2
3	01-0133	Retaining Ring	1
5	61-0051	Serial Number	1
4	61-0086	Plate and Shaft Assy	1
8	61-0097	Hinged Side Plate & Tube Clamp Sub Assy	1
5	61-0143	Impeller Roller Assy	2
9	62-2100	"L" Bracket	1
1	63-0010	Pump Housing	1
11	00-0532	Shim	1

UNLESS OTHERWISE SPECIFIED
 DIMENSIONAL TOLERANCES ARE:
 FRACTIONS DECIMALS ANGLES
 MILLIMETERS:
 N/A ±.127 ±.5°
 INCHES:
 ±1/64 ±.005 ±.5°

CAD GENERATED DRAWING.
 DO NOT MANUALLY UPDATE

randolph austin company 2119 FM 1626
 MANCHACA TX. 78652
 (512) 282-1590

APPROVALS	DATE
DRAWN	8/4/2020
CHECKED	
RESP ENG	
MFG ENG	
QUAL ENG	

**620-PHO, Mounting Dimensions,
 Exploded View and BOM**

SIZE DWG. NO. REV.
 A 620-PHO

SCALE CAD FILE: 620-PHO SHEET 2 OF 3

NEXT ASSY	USED ON
APPLICATION	DO NOT SCALE DRAWING

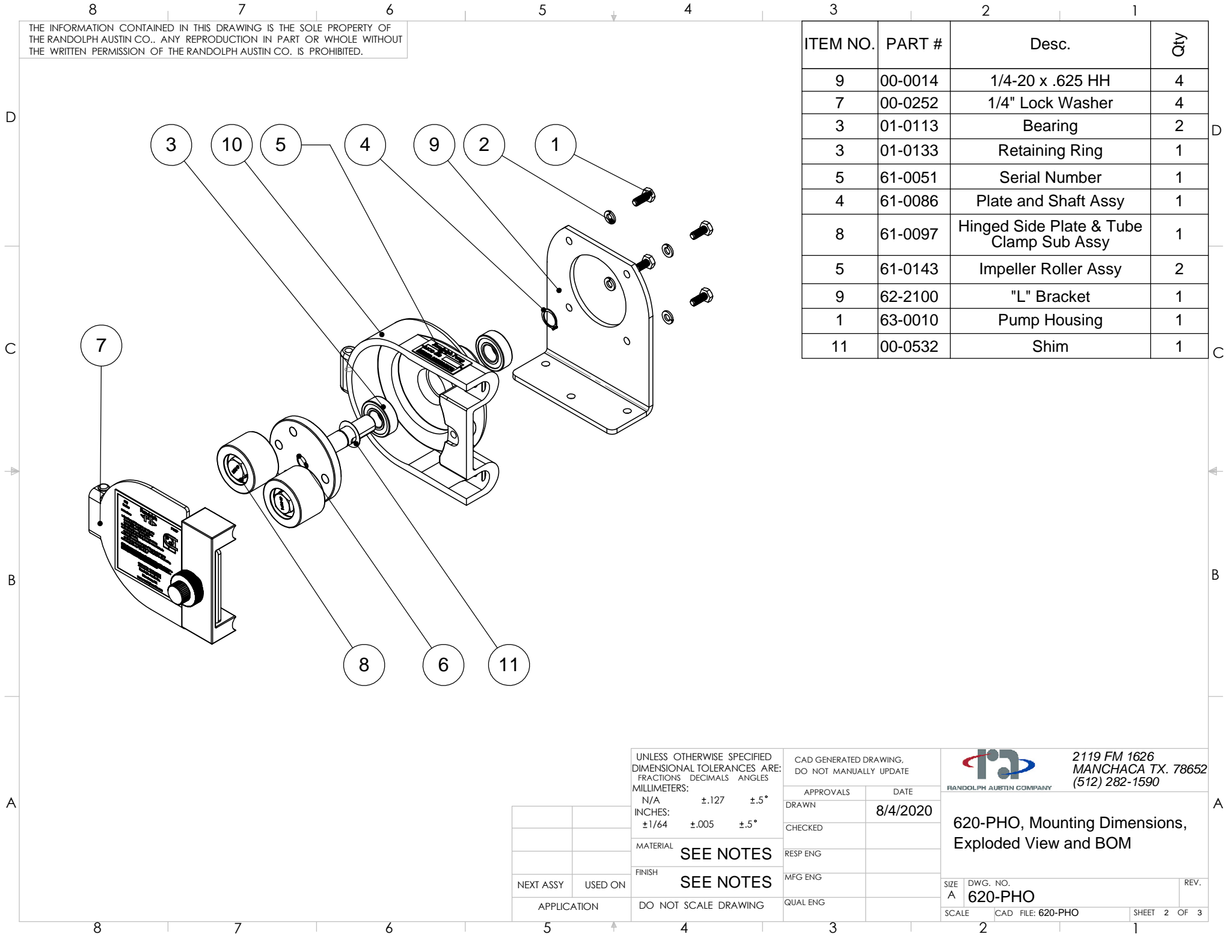

THE INFORMATION CONTAINED IN THIS DRAWING IS THE SOLE PROPERTY OF THE RANDOLPH AUSTIN CO.. ANY REPRODUCTION IN PART OR WHOLE WITHOUT THE WRITTEN PERMISSION OF THE RANDOLPH AUSTIN CO. IS PROHIBITED.

ITEM NO.	PART NO.	DESCRIPTION	QTY.
1	63-0010	620 pump housing machined	1
2	01-0113	Bearing	2
3	01-0133	Snap Ring	1
4	61-0086	Plate and Shaft Assy	1
5	61-0143	Impeller Roller Assembly	3
6	62-2100	"L" Bracket	1
7	00-0252	Washer	4
8	61-0097	Side Plate Sub Assy 610	1
9	00-0014	Screw, Hex, 1/4-20 x 5/8"	4
10	61-0051	620 name plate	1
11	00-0532	Shim	1

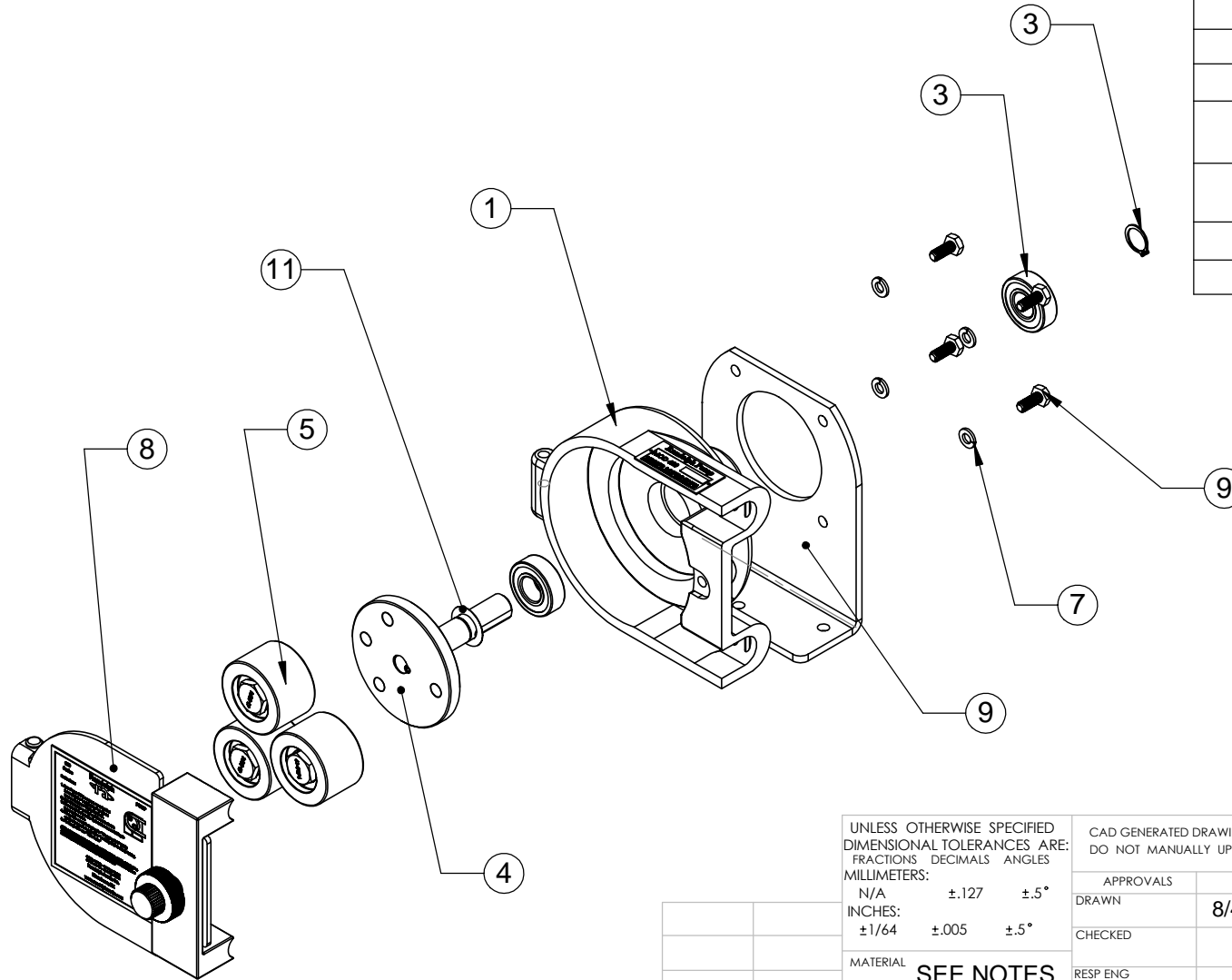

UNLESS OTHERWISE SPECIFIED
 DIMENSIONAL TOLERANCES ARE:
 FRACTIONS DECIMALS ANGLES
 MILLIMETERS:
 N/A ±.127 ±.5°
 INCHES:
 ±1/64 ±.005 ±.5°

CAD GENERATED DRAWING.
 DO NOT MANUALLY UPDATE



2119 FM 1626
 MANCHACA TX. 78652
 (512) 282-1590

APPROVALS	DATE
DRAWN	8/4/2020
CHECKED	
RESP ENG	
MFG ENG	
QUAL ENG	

NEXT ASSY	USED ON
APPLICATION	

MATERIAL **SEE NOTES**
 FINISH **SEE NOTES**
 DO NOT SCALE DRAWING

SIZE	DWG. NO.	REV.
A	620-PHO	
SCALE	CAD FILE: 620-PHO	SHEET 3 OF 3