

THE INFORMATION CONTAINED IN THIS DRAWING IS THE SOLE PROPERTY OF Randolph Austin Company. ANY REPRODUCTION IN PART OR WHOLE WITHOUT THE WRITTEN PERMISSION OF Randolph Austin Company IS PROHIBITED.

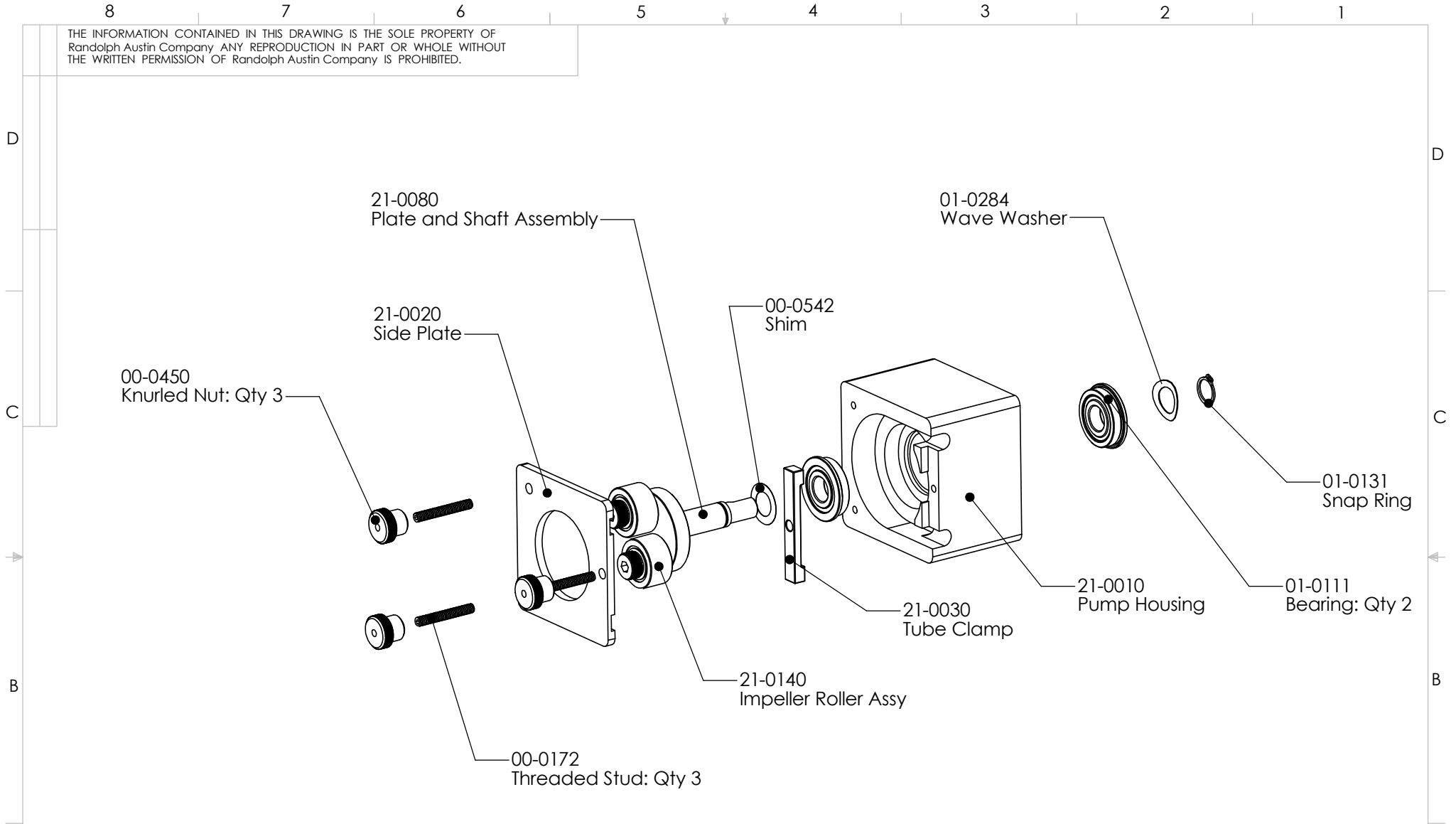

Rev	Description	By	Date
-	New Print	-	09-10-02
-	Wave Washer Added	-	03-28-12

APPLICATION	NEXT ASSY	USED ON

ITEM NO.	PART OR IDENTIFYING NO.	NOMENCLATURE OR DESCRIPTION	MATERIAL SPECIFICATION	QTY REQD
PARTS LIST				
UNLESS OTHERWISE SPECIFIED DIMENSIONS ARE IN INCHES TOLERANCES ARE:		CAD GENERATED DRAWING. DO NOT MANUALLY UPDATE		Randolph Austin Company Exploded View: 250 Pump
FRACTIONS DECIMALS ANGLES +/- 1/64 .XX +/- .01 + 1		APPROVALS	DATE	
MATERIAL --		DRAWN		
FINISH --		CHECKED		
DO NOT SCALE DRAWING		RESP ENG		
		MFG ENG		
		QUAL ENG		
SIZE A	DWG. NO.	250-PHO		REV.
SCALE	CAD FILE:	SHEET	OF	

REVISIONS		DATE	APPROVED
ZONE	REV.	DESCRIPTION	

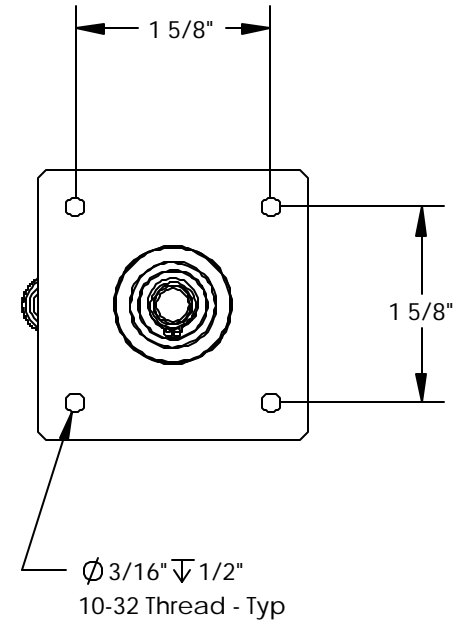
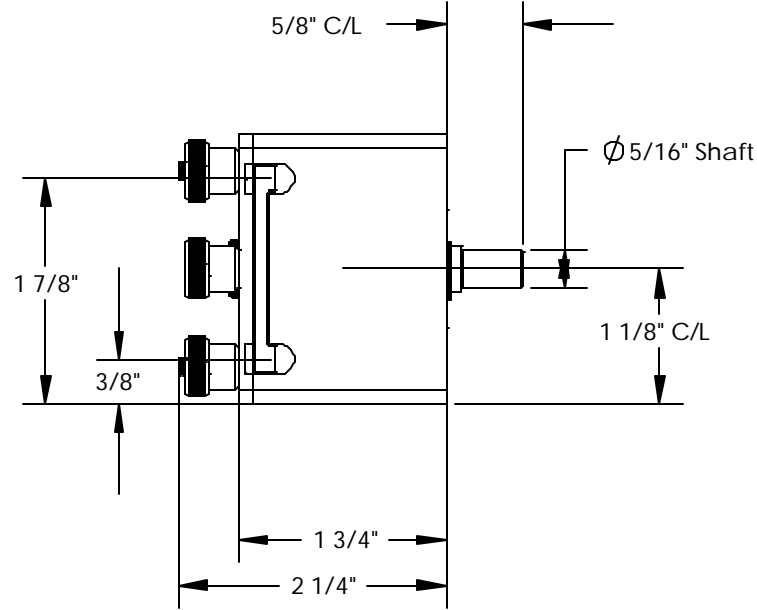
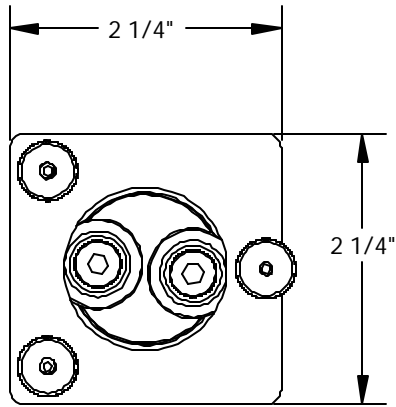

PROPRIETARY AND CONFIDENTIAL
 THE INFORMATION CONTAINED IN THIS DRAWING IS THE SOLE PROPERTY OF Randolph Austin Company. ANY REPRODUCTION IN PART OR AS A WHOLE WITHOUT THE WRITTEN PERMISSION OF Randolph Austin Company IS PROHIBITED.

		DIMENSIONS ARE IN INCHES TOLERANCES: FRACTIONAL $\pm 1/64$ ANGULAR: MACH ± 1 TWO PLACE DECIMAL $\pm .01$ THREE PLACE DECIMAL $\pm .005$		NAME	DATE	Randolph Austin Co
		MATERIAL --		DRAWN		
		FINISH --		CHECKED		250 Pump Head Mounting Dimensions
NEXT ASSY	USED ON			ENG APPR.		
APPLICATION		DO NOT SCALE DRAWING		MFG APPR.		
				Q.A.		
				COMMENTS:		SIZE A
						DWG. NO. 250-PHO-MD
						REV.
						SCALE:1:1
						WEIGHT:
						SHEET 1 OF 1